



## 4 x 35W QUAD BRIDGE CAR RADIO AMPLIFIER

- HIGH OUTPUT POWER CAPABILITY:
  - 4 x 40W/4Ω MAX.
  - 4 x 35W/4Ω EIAJ
  - 4 x 25W/4Ω @ 14.4V, 1KHz, 10%
  - 4 x 22W/4Ω @ 13.2V, 1KHz, 10%
- LOW DISTORTION
- LOW OUTPUT NOISE
- ST-BY FUNCTION
- MUTE FUNCTION
- AUTOMUTE AT MIN. SUPPLY VOLTAGE DETECTION
- LOW EXTERNAL COMPONENT COUNT:
  - INTERNALLY FIXED GAIN (26dB)
  - NO EXTERNAL COMPENSATION
  - NO BOOTSTRAP CAPACITORS

### PROTECTIONS:

- OUTPUT SHORT CIRCUIT TO GND, TO  $V_S$ , ACROSS THE LOAD
- VERY INDUCTIVE LOADS
- OVERRATING CHIP TEMPERATURE WITH SOFT THERMAL LIMITER
- LOAD DUMP VOLTAGE

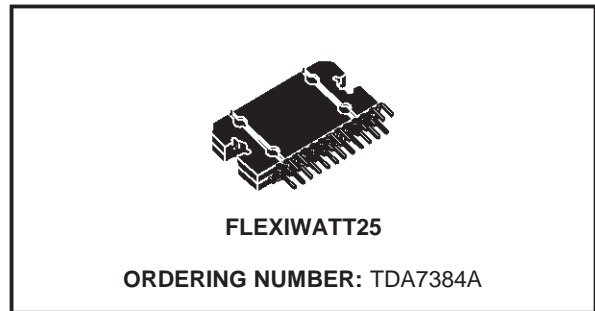

- FORTUITOUS OPEN GND
- REVERSED BATTERY
- ESD

### DESCRIPTION

The TDA7384A is a new technology class AB Audio Power Amplifier in Flexiwatt 25 package designed for high end car radio applications.

Thanks to the fully complementary PNP/NPN output configuration the TDA7384A allows a rail to rail output voltage swing with no need of bootstrap capacitors. The extremely reduced components count allows very compact sets.

### BLOCK AND APPLICATION DIAGRAM

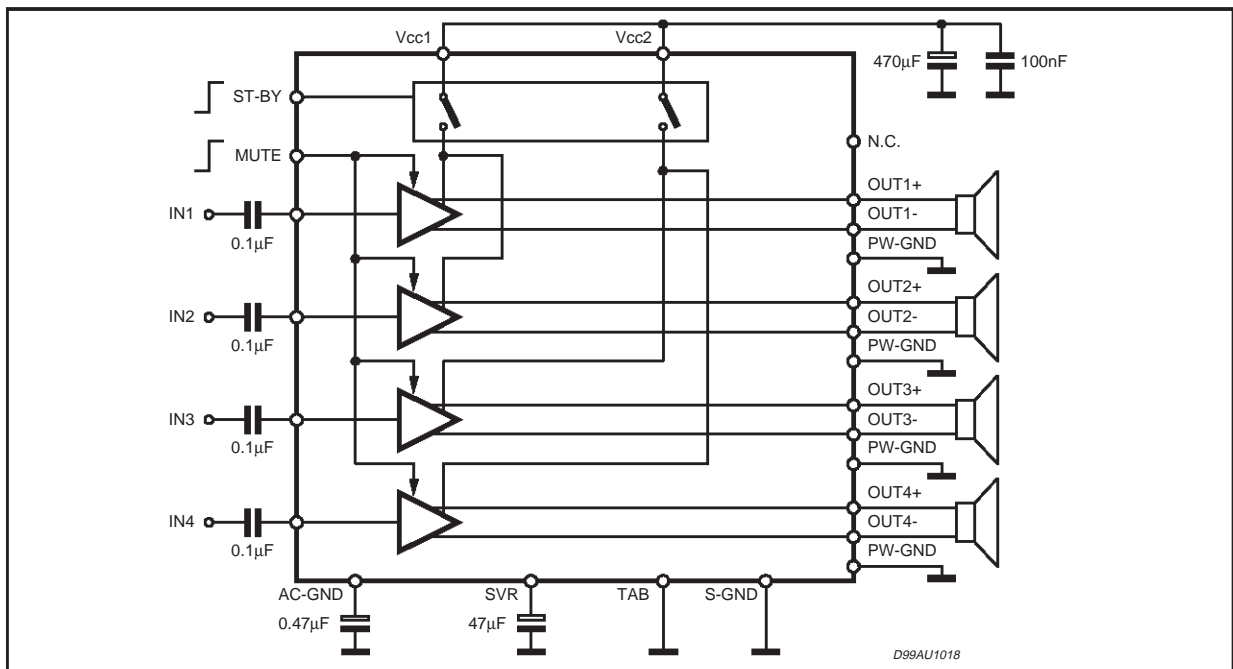

# TDA7384A

## ABSOLUTE MAXIMUM RATINGS

Symbol	Parameter	Value	Unit
$V_{CC}$	Operating Supply Voltage	18	V
$V_{CC(DC)}$	DC Supply Voltage	28	V
$V_{CC(pk)}$	Peak Supply Voltage (t = 50ms)	50	V
$I_o$	Output Peak Current: Repetitive (Duty Cycle 10% at f = 10Hz)	4.5	A
	Non Repetitive (t = 100 $\mu$ s)	5.5	A
$P_{tot}$	Power dissipation, (T <sub>case</sub> = 70°C)	80	W
$T_j$	Junction Temperature	150	°C
$T_{stg}$	Storage Temperature	- 55 to 150	°C

## PIN CONNECTION (Top view)

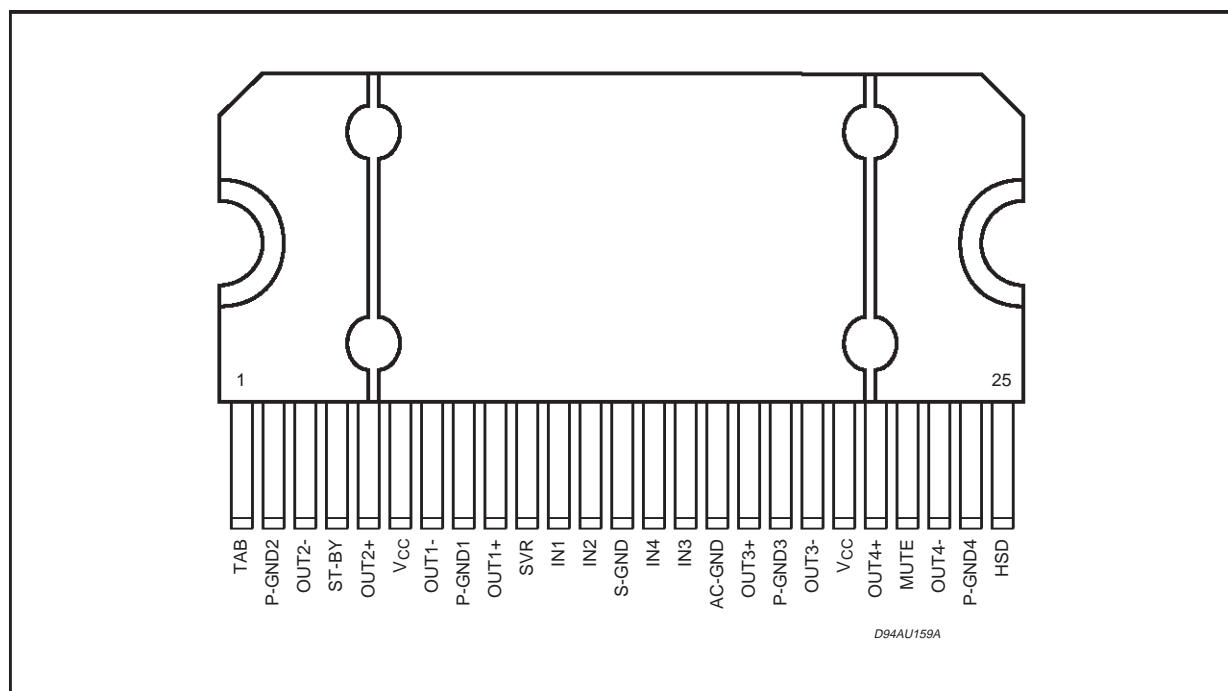

## THERMAL DATA

Symbol	Parameter	Value	Unit
$R_{th j-case}$	Thermal Resistance Junction to Case	Max. 1	°C/W

**ELECTRICAL CHARACTERISTICS** ( $V_S = 14.4V$ ;  $f = 1KHz$ ;  $R_g = 600\Omega$ ;  $R_L = 4\Omega$ ;  $T_{amb} = 25^\circ C$ ;  
Refer to the test and application diagram, unless otherwise specified.)

Symbol	Parameter	Test Condition	Min.	Typ.	Max.	Unit
$I_{q1}$	Quiescent Current	$R_L = \infty$	120	190	350	mA
$V_{OS}$	Output Offset Voltage	Play Mode			$\pm 80$	mV
$dV_{OS}$	During mute ON/OFF output offset voltage				$\pm 80$	mV
$G_v$	Voltage Gain		25	26	27	dB
$dG_v$	Channel Gain Unbalance				$\pm 1$	dB
$P_o$	Output Power	$V_S = 13.2V$ ; THD = 10% $V_S = 13.2V$ ; THD = 0.8% $V_S = 14.4V$ ; THD = 10%	20 15 24	22 17 26		W W W
$P_{o\ EIAJ}$	EIAJ Output Power (*)	$V_S = 13.7V$	32	35		W
$P_{o\ max.}$	Output Power (*)	$V_S = 14.4V$	38	40		W
THD	Distortion	$P_o = 4W$		0.04	0.15	%
$e_{No}$	Output Noise	"A Weighted" Bw = 20Hz to 20KHz		50 70	70 100	$\mu V$ $\mu V$
SVR	Supply Voltage Rejection	$f = 100Hz$ ; $V_r = 1V_{rms}$	50	65		dB
$f_{ch}$	High Cut-Off Frequency	$P_o = 0.5W$	100	200		KHz
$R_i$	Input Impedance		70	100		K $\Omega$
$C_T$	Cross Talk	$f = 1KHz$ $P_o = 4W$ $f = 10KHz$ $P_o = 4W$	60 50	70 60	- -	dB dB
$I_{SB}$	St-By Current Consumption	$V_{St-By} = 1.5V$			100	$\mu A$
$I_{pin4}$	St-by pin Current	$V_{St-By} = 1.5V$ to $3.5V$			$\pm 10$	$\mu A$
$V_{SB\ out}$	St-By Out Threshold Voltage	(Amp: ON)	3.5			V
$V_{SB\ in}$	St-By in Threshold Voltage	(Amp: OFF)			1.5	V
$A_M$	Mute Attenuation	$P_{Oref} = 4W$	80	90		dB
$V_{M\ out}$	Mute Out Threshold Voltage	(Amp: Play)	3.5			V
$V_{M\ in}$	Mute In Threshold Voltage	(Amp: Mute)			1.5	V
$V_{AM\ in}$	$V_S$ Automute Threshold	(Amp: Mute) Att $\geq 80dB$ ; $P_{Oref} = 4W$ (Amp: Play) Att $< 0.1dB$ ; $P_o = 0.5W$			6.5	V
$I_{pin22}$	Muting Pin Current	$V_{MUTE} = 1.5V$ (Sourced Current)	5	11	20	$\mu A$

(\*) Saturated square wave output.

Figure 1: Standard Test and Application Circuit

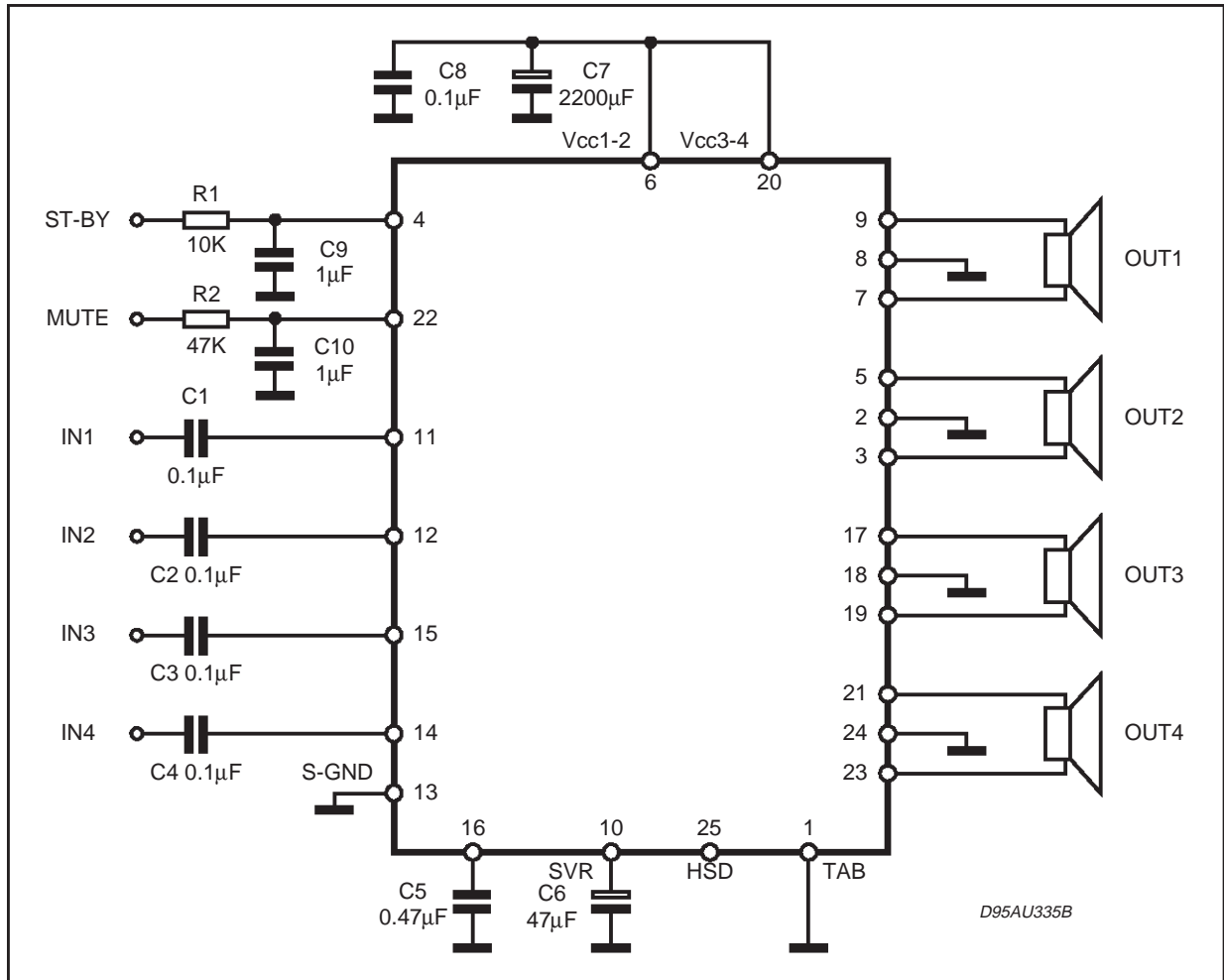

Figure 3: Quiescent Current vs. Supply Voltage

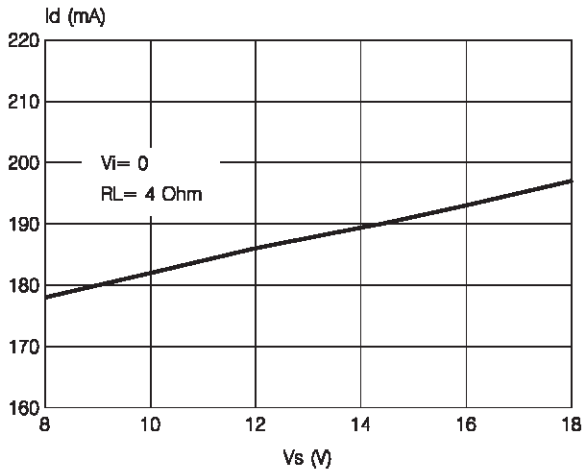

Figure 4: Quiescent Output Voltage vs. Supply Voltage

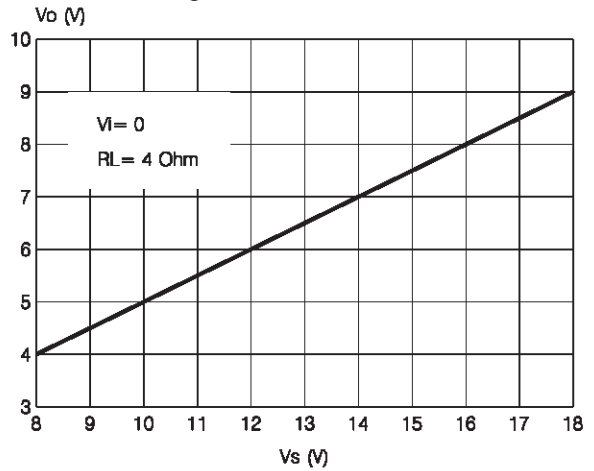

Figure 5: Output Power vs. Supply Voltage

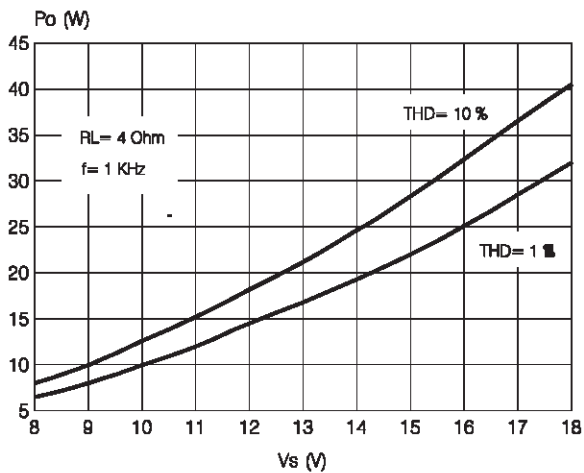

Figure 6: Distortion vs. Output Power

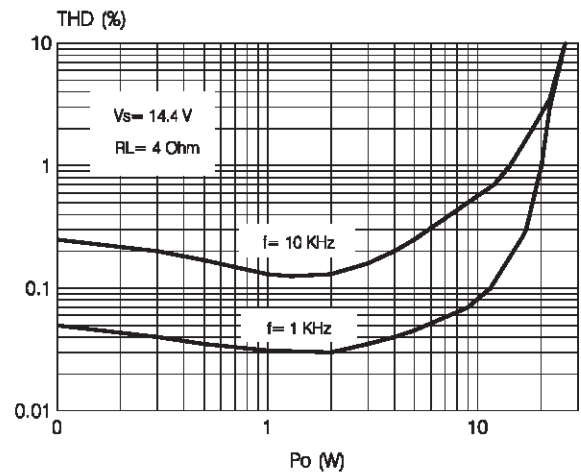

Figure 7: Distortion vs. Frequency

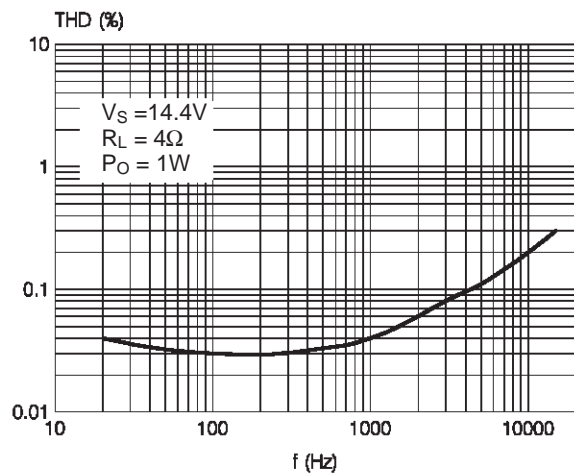
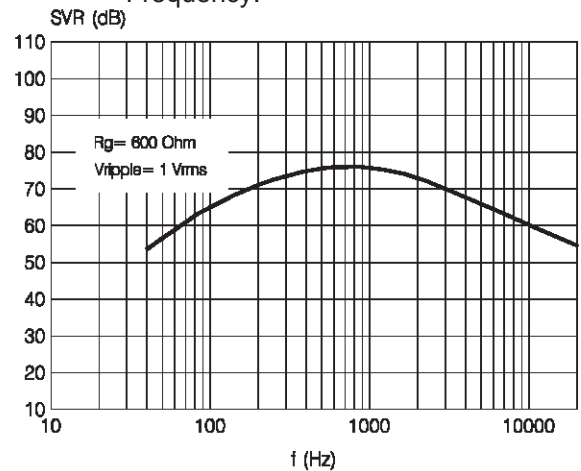

Figure 8: Supply Voltage Rejection vs. Frequency.



# TDA7384A

DIM.	mm			inch		
	MIN.	TYP.	MAX.	MIN.	TYP.	MAX.
A	4.45	4.50	4.65	0.175	0.177	0.183
B	1.80	1.90	2.00	0.070	0.074	0.079
C		1.40			0.055	
D	0.75	0.90	1.05	0.029	0.035	0.041
E	0.37	0.39	0.42	0.014	0.015	0.016
F (1)			0.57			0.022
G	0.80	1.00	1.20	0.031	0.040	0.047
G1	23.75	24.00	24.25	0.935	0.945	0.955
H (2)	28.90	29.23	29.30	1.138	1.150	1.153
H1		17.00			0.669	
H2		12.80			0.503	
H3		0.80			0.031	
L (2)	22.07	22.47	22.87	0.869	0.884	0.904
L1	18.57	18.97	19.37	0.731	0.747	0.762
L2 (2)	15.50	15.70	15.90	0.610	0.618	0.626
L3	7.70	7.85	7.95	0.303	0.309	0.313
L4		5			0.197	
L5		3.5			0.138	
M	3.70	4.00	4.30	0.145	0.157	0.169
M1	3.60	4.00	4.40	0.142	0.157	0.173
N		2.20			0.086	
O		2			0.079	
R		1.70			0.067	
R1		0.5			0.02	
R2		0.3			0.12	
R3		1.25			0.049	
R4		0.50			0.019	
V			5° (Typ.)			
V1			3° (Typ.)			
V2			20° (Typ.)			
V3			45° (Typ.)			

(1): dam-bar protusion not included  
 (2): molding protusion included

## OUTLINE AND MECHANICAL DATA

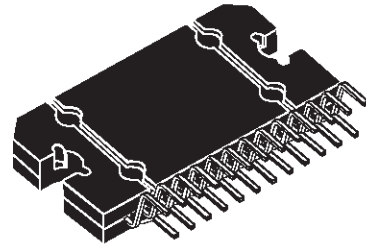

## Flexiwatt25

